

GENERAL DESCRIPTION

CM6901 is a SLS, SRC/LLC + SR resonant controller and it can operate at both SRC and LLC region with synchronous rectification to achieve high efficiency. Its unique features: FM + 2 PWMING modes. It is used for DC-DC conversion in offline application.

Light load regulation is accomplished by transitioning the controller from frequency modulation mode into PWM mode. We call this is Light load PWMING function. When ac turn off, bulk input voltage will drop. The switching frequency is below the highest resonant point frequency $f_{r1} = 1 / 2\pi \sqrt{LrCr}$; Lr: resonant choke; Cr: resonant cap. SR Ideal Diode PWMING for synchronous drivers is accomplished by comparing the voltage signal at the RSET pin to RTCT ramp. The pulse-width reduction will happen when switching frequency below the highest resonant point frequency f_{r1} . The CM6901 have FM + 2 PWMING modes to have the optimal balance performance between hold-up time and efficiency. The operate region shown as fig1.

CM6901 system has a constant voltage feedback loop with precision 2.5V VFB reference. The 1V ILIMIT can be latched when a standby converter is applied; otherwise, it is an auto-restart I limit.

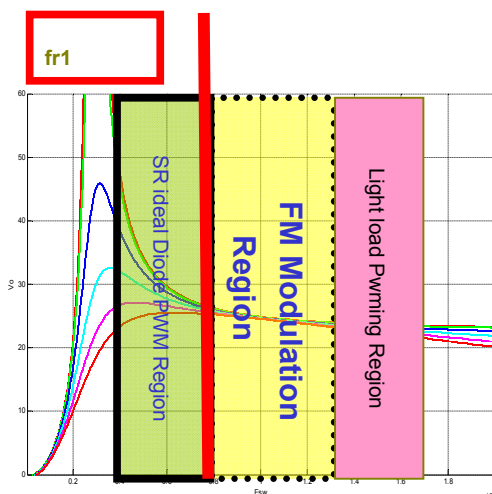

Fig1 FM+2 PWMING mode

FEATURES

- ◆ 90+ Controller
- ◆ Smaller and Thinner Transformer
- ◆ 20ms with reasonable Bulk Cap(hold up time)
- ◆ SLS, SRC/LLC + SR resonant controller
- ◆ 2 Gate Drivers: Typical Peak Drive from 12V supply : (PMOS~200 ohm and NMOS~100 ohm).
- ◆ UVLO =11V with 1V Hysteresis.
- ◆ Reference OK Comparator.
- ◆ FM + 2 PWMING Mode Operation
- ◆ Light Load PWMING (light load regulation)
- ◆ SR Ideal Diode PWMING(cross resonant frequency application)
- ◆ GM FEAO, FM modulation Error Amplifier
- ◆ GM DEAO, PWM Error Amplifier
- ◆ Soft start Capability with Shutdown Function.
- ◆ Auto-Restart during Current LIMIT.
- ◆ Precision 2.5V VFB threshold for constant voltage feedback loop.
- ◆ Precision 1V I limit threshold (ILIM).
- ◆ Patented

APPLICATIONS

- ◆ DC-DC Power Supply.

CM6901 Pin Configuration

Top View

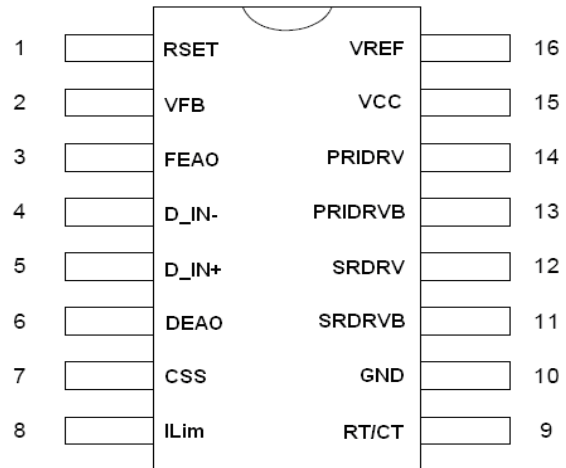

ORDERING INFORMATION

Part Number	Temperature Range	Package
CM6901XIS*	-40°C to 125°C	16-Pin SOP (S16)
CM6901XISTR*	-40°C to 125°C	16-Pin SOP (S16)
CM6901XIP*	-40°C to 125°C	16-Pin PDIP (P16)

- * X : Suffix for Halogen Free and PB Free Product
- TR : Package is Tape & Reel

THERMAL DATA

PARAMETER	Min	MAX	Unit
Junction Temperature		150	°C
Thermal Resistance (θ_{JA})			
Plastic DIP		80	°C/W
Plastic SOP		105	°C/W
Case Temperature (θ_{JC})			
Plastic DIP		21.8	°C/W
Plastic SOP		31.25	°C/W

BLOCK DIAGRAM

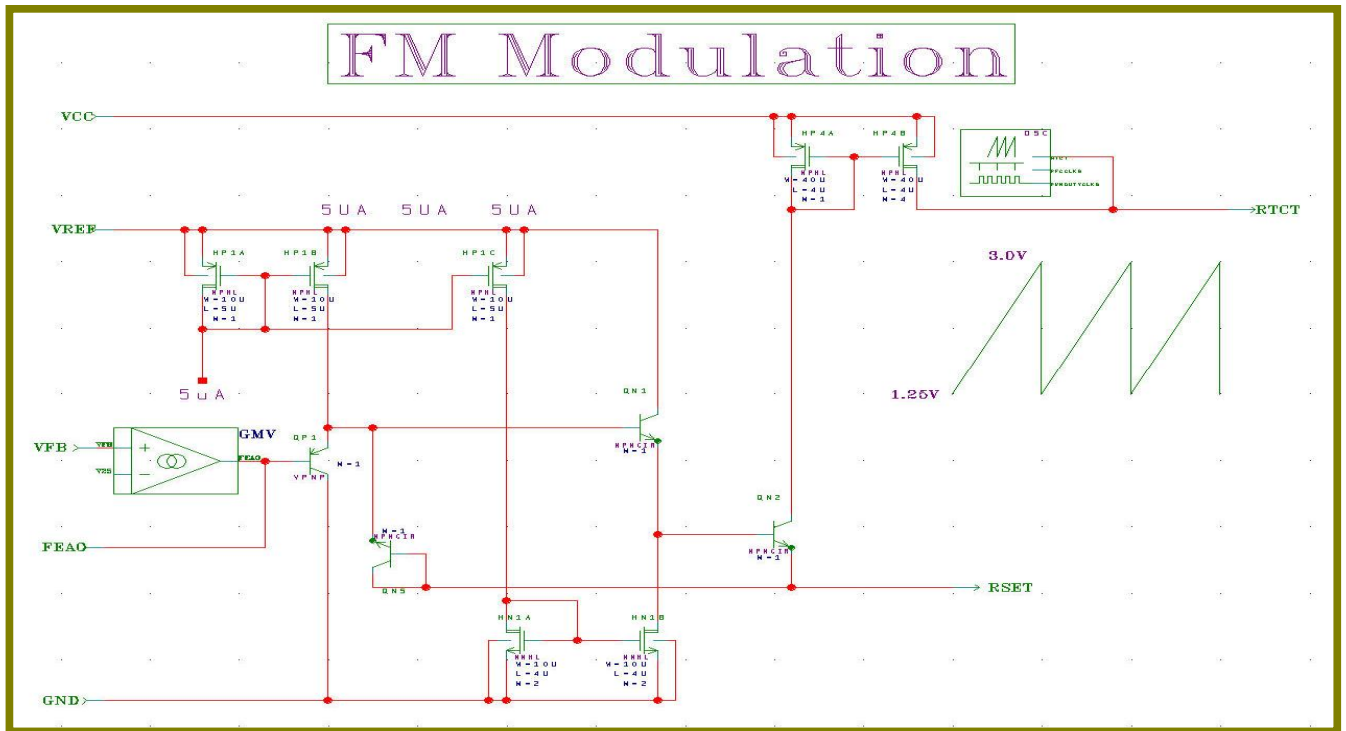
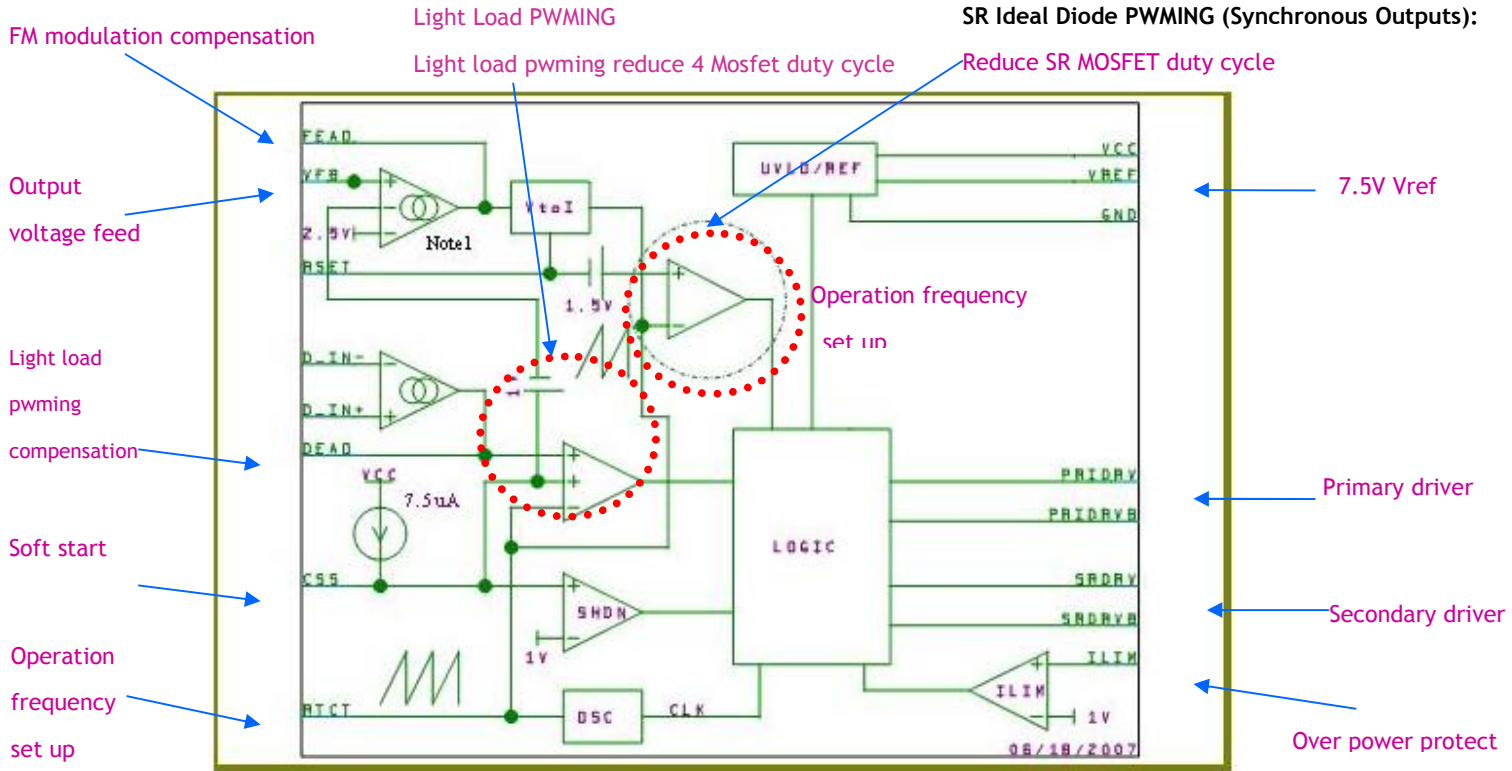

PIN DESCRIPTION

Pin No.	Symbol	Description	Operating Voltage			
			Min.	Typ.	Max.	Unit
1	RSET	External resistor which convert FEAO voltage signal into current signal (V to I) for frequency modulation. SR is PWMING Control , when RSET lower than 1.5V.	0		5.5	V
2	VFB	Non-inverting input into resonant error amplifier .	0	2.5	3	V
3	FEAO	Resonant error amplifier output and compensation node for frequency modulation control.	0		5.5	V
4	D_IN-	Inverting input into Light load PWMING error mode amplifier.	0		6	V
5	D_IN+	Non-inverting input into Light load PWMING mode error amplifier.	0		6	V
6	DEAO	PWM error amplifier output and compensation node for Light load PWMING control	0		4.5	V
7	CSS	Soft start for FM/PWM operation with 1V enable threshold. Also, use for auto-restart operation during current limit.	0		5.5+VBE	V
8	ILIM	Sense Input to current comparator with 1V threshold.	0	1	1.25	V
9	RTCT	Oscillator timing components which set the minimum frequency.	1.2		3	V
10	GND	Ground				
11	SDRVB	Synchronous MOSFET driver output.	-0.3		VCC	V
12	SDRV	Synchronous MOSFET driver output.	-0.3		VCC	V
13	PRIDRVB	Primary side MOSFET driver output.	-0.3		VCC	V
14	PRIDRV	Primary side MOSFET driver output.	-0.3		VCC	V
15	VCC	Positive supply for the IC	10	15	20	V
16	VREF	Buffered output for the 7.5V voltage reference		7.5		V

ABSOLUTE MAXIMUM RATINGS

(TA=25°C, unless otherwise specified.)

The following ratings designate persistent limits beyond which damage to the device may occur.

Symbol	Parameter	Value	Unit
VCC	DC Supply Voltage	21	V
SRDRV	SRDRV Voltage	GND-0.3 to VCC+0.3	V
SRDRVB	SRDRVB Voltage	GND-0.3 to VCC+0.3	V
PRIDRV	PRIDRV Voltage	GND-0.3 to VCC+0.3	V
PRIDRVB	PRIDRVB Voltage	GND-0.3 to VCC+0.3	V
Driver (Pin11~Pin14)	Driver Voltage (period less than 50ns)	GND-3.0 to VCC+0.3	V
	Driver Voltage (period less than 25ns)	GND-5.0 to VCC+0.3	V
	Driver Out Sink or Source	0.12	A
	Driver Out Sink or Source (period less than 5us)	0.25	A
VREF	VREF Voltage	GND-0.3 to 8	V
VREF	VREF Transient Voltage (period less than 2ms)	8.5	V
VREF	VREF Transient Voltage (period less than 300us)	10	V
IREF	VREF Current	5	mA
RTCT	RTCT Voltage	-0.3 to VREF+0.3	V
VILIM	VILIM Voltage	-0.3 to VREF+0.3	V
CSS	CSS Voltage	-0.3 to VREF+0.3	V
DEAO	PWM Error Amplifier Output Voltage	-0.3 to VREF+0.3	V
D_IN+	Non-Inverting Input Into PWM Error Amplifier Voltage	-0.3 to VREF+0.3	V
FEAO	Resonant Error Amplifier Output Voltage	-0.3 to VREF+0.3	V
VFB	Non-Inverting Input Into Resonant Error Amplifier Voltage	-0.3 to VREF+0.3	V
RSET	V to I Voltage	-0.3 to VREF+0.3	V

IC Test Equivalent External Circuit

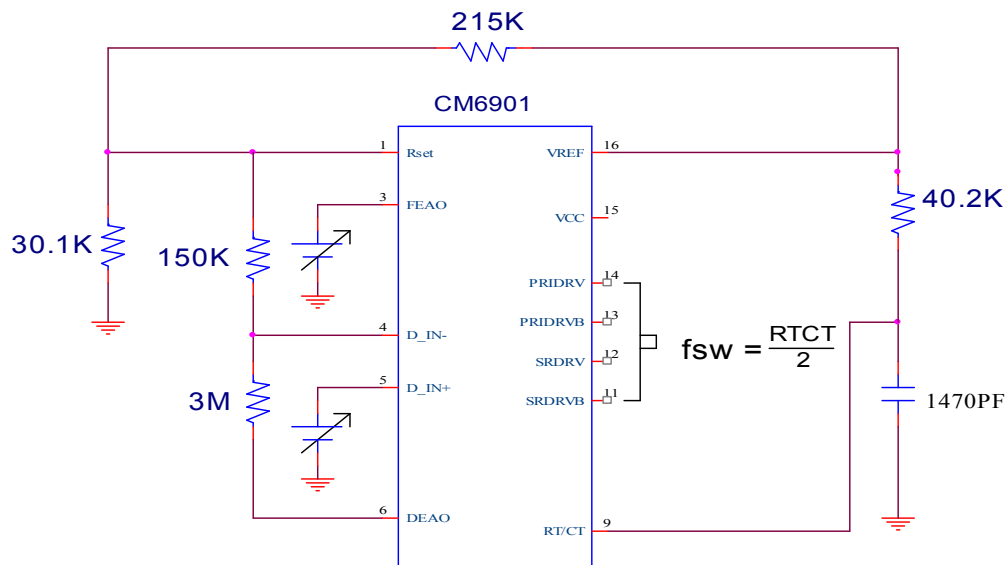

ELECTRICAL CHARACTERISTICS

(VCC=12V, RT=40.2K±1%, CT=1470PF±1%, Freq. = 50 KHz, Duty Cycle=48% , Temp= -40 ~ 125 °C, unless otherwise specified.)

Parameter	Symbol	Conditions	Min.	Typ.	Max.	Unit
VREF (pin 16) test						
Reference Voltage (note1)	VREF	TA=25°C; Iref=1mA	7.41	7.5	7.59	V
	VREF	TA=-40°C; Iref=0mA	7.44	7.53	7.62	V
	VREF	TA=125°C; Iref=0mA	7.53	7.67	7.7	V
Line Regulation		11.5V < Vcc < 16.5V		10	25	mV
Load Regulation		0mA < Iref < 5mA, TA=25°C	0	10	25	mV
VCC (pin 15)						
VCC Start up voltage	Vstart		10.5	10.8	11.1	V
VCC Turn off voltage			9.5	10	10.5	V
VCC Start up current		TA=25°C	63.5	78.25	93	uA
UVLO Hysteresis	Hys		0.95	1	1.05	V
Operating Current	ICC	TA=25°C	0.7	1	1.3	mA
SRDRV , SRDRV , PRIDRV , PRIDRV (pin 11,12,13,14)						
Output Low Voltage	Vol	Isrcrv=-6mA		0.6	1.2	V
Output High Voltage	Voh	Isrcrv=+6mA	9.6	10.8		V
Iout peak source current	Iout			0.12		A
Iout peak sink current	Iout			0.12		A
PMOS Rdson	Rout	TA=25°C		200	250	Ohm
NMOS Rdson	Rout	TA=25°C		100	150	Ohm
Dead Time between PRIDRV and PRIDRVB(TDEAD ¹)	TDead ¹	TA=25°C (CT discharge time)		1		us
Rising Edge Delay Between PRIDRV and SRDRV(TDelay ¹)	TDelay ¹	TA=25°C	164	205	246	ns
Falling Edge Delay Between SRDRV and PRIDRV(TDelay ²)	TDelay ²	TA=25°C	168	210	252	ns
Duty Cycle Range			0		50	%
ILIM (pin 8)						
SS Voltage Hi (SS rise > 5V)		TA=25°C	0.95	1	1.05	V
SS Voltage Low (SS rise < 5V)		TA=25°C	1.31	1.64	1.97	V

ELECTRICAL CHARACTERISTICS

(VCC=12V, RT=40.2K±1%, CT=1470PF±1%, Freq. = 50 KHz, Duty Cycle=48% , Temp=-40 ~ 125°C, unless otherwise specified.)

Parameter	Symbol	Conditions	Min.	Typ.	Max.	Unit
CSS (pin 7)						
Soft Start Current	I _{ss}	TA=25°C	6.7	7.5	8.5	uA
Enable Voltage	V _{en}	TA=25°C	0.9	1.0	1.1	V
Enable Hysteresis	V _{hys}	TA=25°C		100		mV
Auto-restart Upper Threshold	V _{up}		4.85	5.0	5.15	V
Auto-restart Lower Threshold	V _{lw}			1-V _{hyst}		V
FEAO Resonant Error Amplifier (pin 3)						
Input Voltage Range					6	V
Transconductance	G _{MV}	VFB±50mV, TA=25°C	37	49.5	62	umho
VFB (Pin2)						
Feedback Reference Voltage		TA=25°C	2.48	2.5	2.52	V
		TA=125°C	2.49	2.51	2.53	V
		TA=-40°C	2.47	2.49	2.51	V
Input Bias Current			-1	-0.5		uA
UL1950_Vth		Ramp down VFB until PRIDRV turn off	0.25	0.5	0.75	V
Output High Voltage				5.5+V _{BE}		V
Output Low Voltage				0.1	0.4	V
Sink Current		VFB =250mV , TA=25°C	-21.5	-17.55	-13.6	uA
Source Current		VFB = -250mV , TA=25°C	12.4	16.7	21	uA
Open Loop Gain				60		dB
DEAO PWM Error Amplifier (pin 6)						
Input Voltage Range					6	V
Reference Voltage			0.96	1.01	1.06	V
Transconductance	G _m	TA=25°C	95	125	155	umho
Input Bias Current			-1.0	-0.5		uA
Output Voltage High				3+V _{BE}		V
Output Voltage Low				0.1	0.4	V
Sink Current				-5		uA
Source Current				7		uA
Open Loop Gain				60		dB

ELECTRICAL CHARACTERISTICS

Test conditions:

(VCC=12V, RT=40.2K±1%, CT=1470PF±1%, Freq. = 50 KHz, Duty Cycle=48% , Temp=-40 ~ 125 °C, unless otherwise specified.)

Parameter	Symbol	Conditions	Min.	Typ.	Max.	Unit
RTCT Oscillator test ; RT=40.2K±1%;CT=1470pF±1%, (pin 9)						
Initial Accuracy		TA=25°C	48.5	50	51.5	Khz
Voltage Stability		11.5V < Vcc < 16.5V		1		%
Temperature Stability				2		%
Ramp Valley to Peak Voltage		Peak voltage:3V;Valley voltage:1.25V		2		V
CT Discharge Time (TDEAD ¹)				1		uS
Maximum Duty cycle	Duty test	When DEAO > 3.0V		48		%
Minimum Duty Cycle	Duty test	When DEAO < 1.2V		0		%
SR Ideal Diode function test:						
Rset1=30.1K±1% ; Rset2=215K±1% (pin12) Pin1 to Gnd=Rset1; Pin1 to Vref=Rset2;Rdeao1=150K;Rdeao2=3M;D_in+=4.5V						
Maximum Duty cycle		TA=25°C , When Feao=2.2V	41.8	44	46.2	%
		FEAO=2.2V at frequency (define resonant frequency)	38	40	46.2	KHZ
Minimum Duty cycle		TA=25°C , sweep Feao; when FEAO=1.57V	26.37	29.3	32.23	%
Frequency at Minimum Duty cycle		TA=25°C , when FEAO=1.57V	23.62	25	27.04	KHz

Note : “ DO NOT SET D+ > 4.5V unless you want to disable ‘Light Load PWMing’
 “ If Rdeao2/Rdeao1 gain is lower, D+ needs to even lower”.

TIMING DIAGRAM

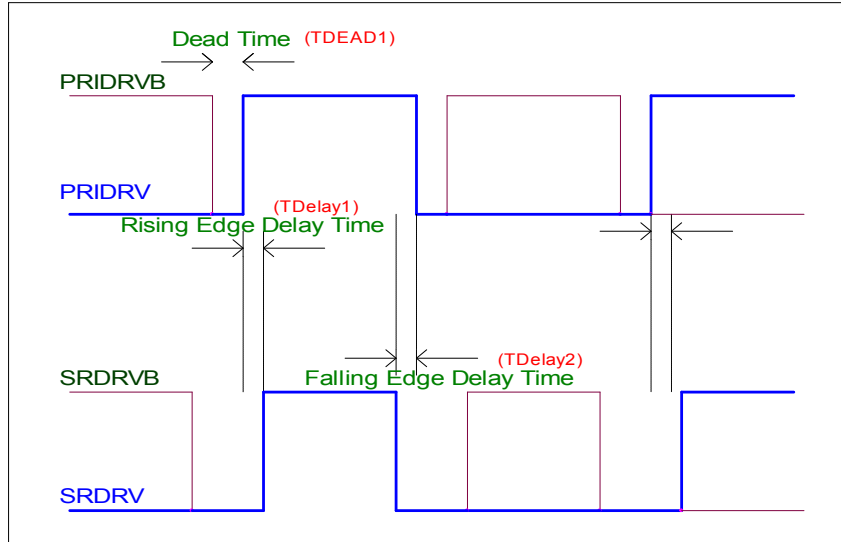

OSCILLATOR

The oscillator frequency is determined by the values of RT and CT.

Design for RT/CT frequency:

$$f_{osc} = 1 / (t_{RAMP} + t_{DEADTIME})$$

$$t_{RAMP} = RT * CT * \ln((V_{REF} + I_{CHG} * RT - 1.25) / (V_{REF} + I_{CHG} * RT - 3)) \text{ where}$$

$$I_{CHG} = I_{CHG \text{ current}} = 4 * (FEAO - V_{BE}) / R_{SET1} - (V_{REF} - V_{Rset}) / R_{set2} + ((D_{in+}) - V_{Rset}) / R_{deao1}$$

4 for current mirror multiply 4

RSET1=Pin 1 to Gnd resistor; Pin9 RTCT peak voltage=3V; valley=1.25V

(TDEAD¹): Dead Time between PRIDRV and PRIDRVB: Discharge CT

$$t_{DEADTIME} = 770 * CT$$

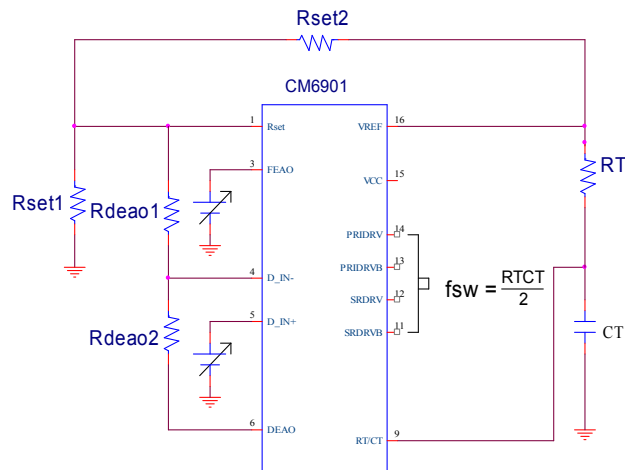

RESONANT SECTION

FM Modulator

Frequency modulation of the resonant controller section is accomplished by controlling the **charging current** of the oscillator through resonant error amplifier. The switching frequency of the resonant section is $\frac{1}{2}$ of the oscillator frequency (RT/CT). Compensation is accomplished by connecting R and C in series to the FEAO pin.

2 PWMINGS :

SR Ideal Diode PWMING (Synchronous Outputs)

SR Ideal Diode PWMING for synchronous drivers is accomplished by comparing the voltage signal at the RSET pin to RTCT ramp. The pulse-width reduction happens when the voltage at the RSET is lower than 1.5V. This allows safe operation of the power converter with synchronous rectification when the switching frequency is **below the highest resonant point frequency fr1**. Avoid Mosfet revise current in SR application.

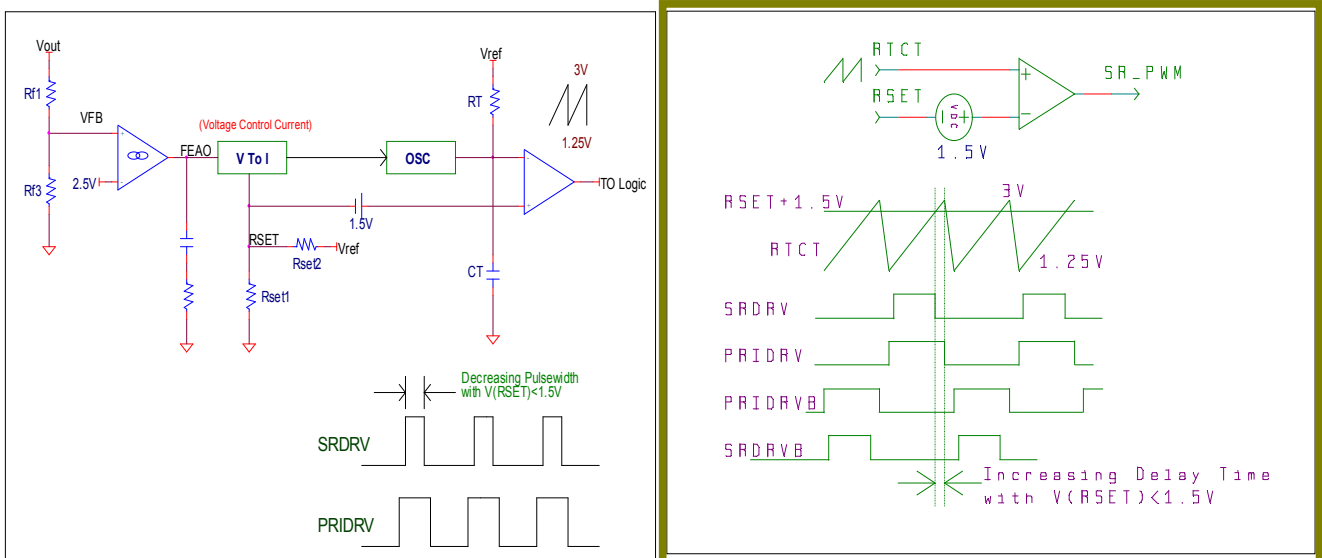

SR Ideal Diode PWMING

Light Load PWMING

In a typical Application , low gain configuration accomplished by connecting R_{deao1} and R_{deao2} in the closed loop configuration . The gain for the PWM is determined by R_{deao1} and R_{deao2} where the gain is equal to $-R_{deao2}/R_{deao1}$. The voltage of V_{Rset} at which the controller goes into FM and PWM simultaneously is equal to :

$$V_{Rset} = D_{IN+} \times (1 + R_{deao1}/R_{deao2}) - (R_{deao1}/R_{deao2}) \times 3$$

where 3 is the peak voltage of RTCT

Vary in R_{set} from V_{Rset} to $V_{Rset} + 1.75 \times R_{deao1}/R_{deao2}$ will cause the duty cycle to vary from 50% to 0% while the frequency will vary proportionally according to $1.75 \times R_{deao1}/R_{deao2}$ where 1.75 is the peak-to-peak voltage of the RTCT ramp. For proper operation, select R_{deao2} value so that the current through R_{deao2} $\{((D_{IN+}) - 1.25)/R_{deao2}\}$ should be less than 5uA.

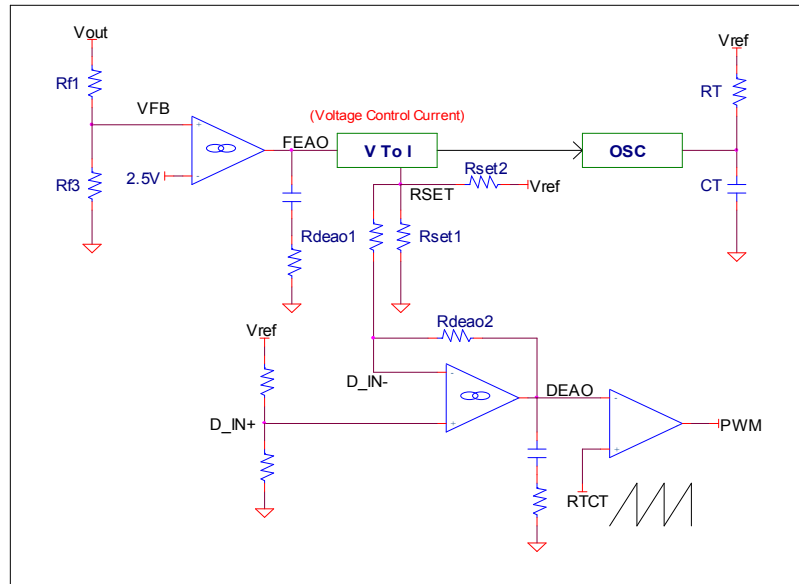

Soft Start and Enable

Soft start of the FM and PWM is controlled by the selection of the external capacitor at CSS pin (**note1**). A typical current source of 7.5uA supplies the charging current for the capacitor. Soft start of the FM and PWM begins at 1V. When SS is less than 1V, FEAO is forced to 5.25V+VBE by internal circuit. When SS is above 1V, FEAO is no longer forced to 5.25V + VBE. As soon as SS is above 1V, FEAO frequency modulation loop becomes active $(VFB-(SS-1)*GMV)$ and FEAO Voltage will be determined by the FEAO error amplifier which is a function of SS signal and the VFB signal. When ss rise reach to 3.5V, it mean main converter into close loop control. The soft start pin CSS also serves as an enable function. The output drivers are enabled when CSS pin reached 1V.

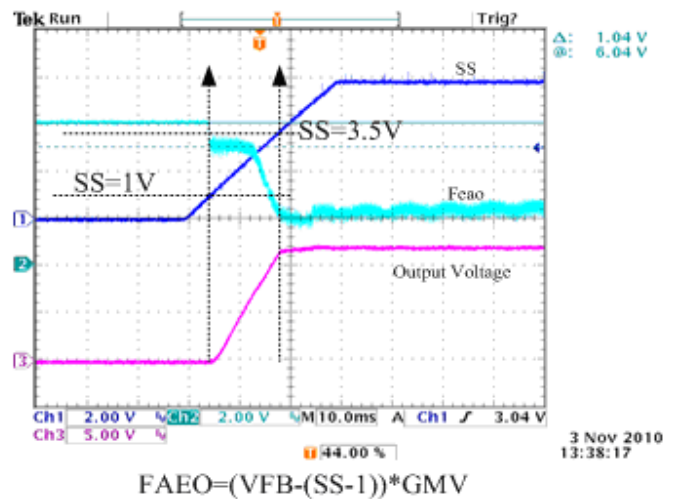
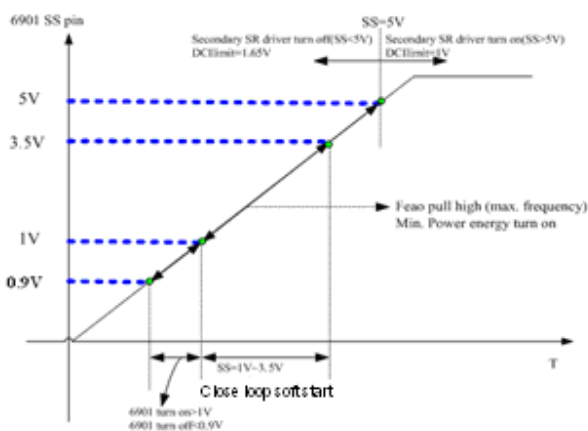

Auto-retry Mode

During normal operation, CSS pin will be charged to $5.5V + V_{BE}$.

- a) VFB less than 0.5V avoid VFB short to GND.
- b) ILIM exceeds 1V due to over current condition.

Output drivers are immediately set to low, and CSS begins to discharge with 0.75uA current source. When CSS pin is below 0.9V, 7.5uA current source start charging the CSS pin. When CSS pin reaches 1V, the output drivers are re-enable and the controller goes into soft start mode. If over current condition still exists then, the outputs are immediately disabled, but CSS continues to charge toward 5V. When CSS reaches 5V, 7.5uA charging current is disabled and 0.75uA current source begins to discharge the CSS, and the cycle repeat until over current condition is removed.

OCP Setting

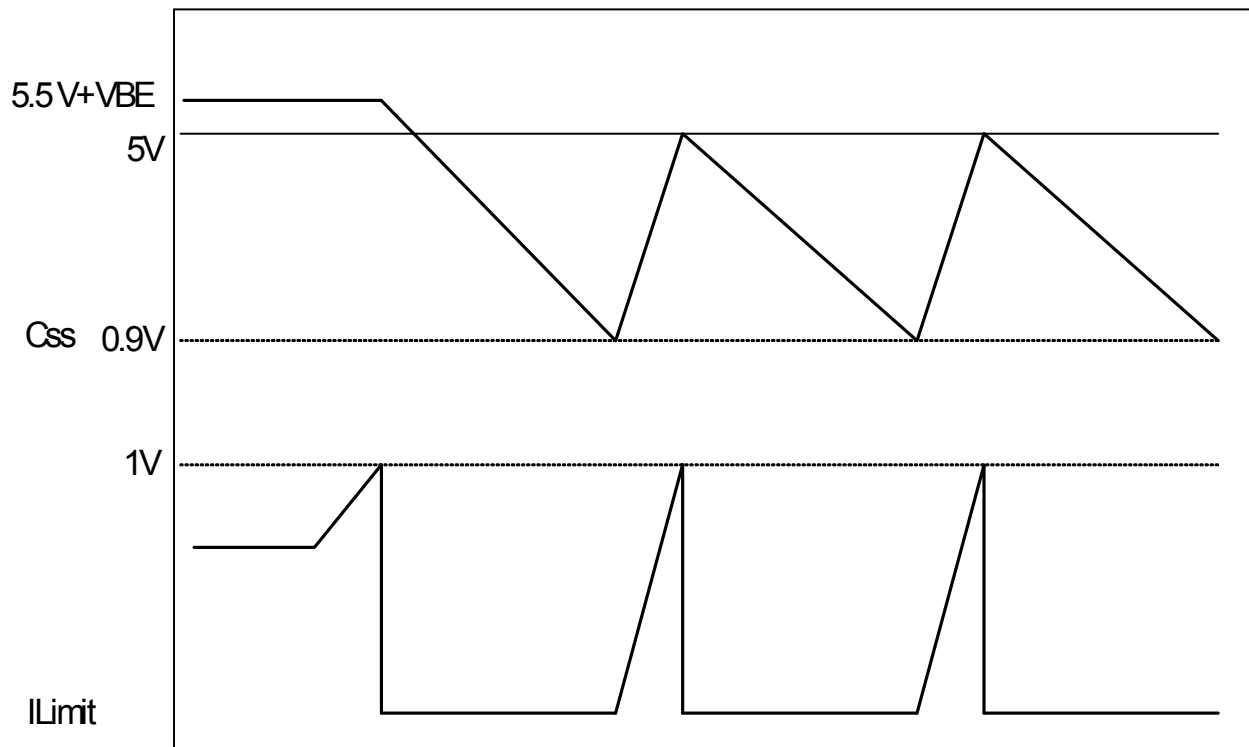

TYPICAL APPLICATION CIRCUIT

PFC

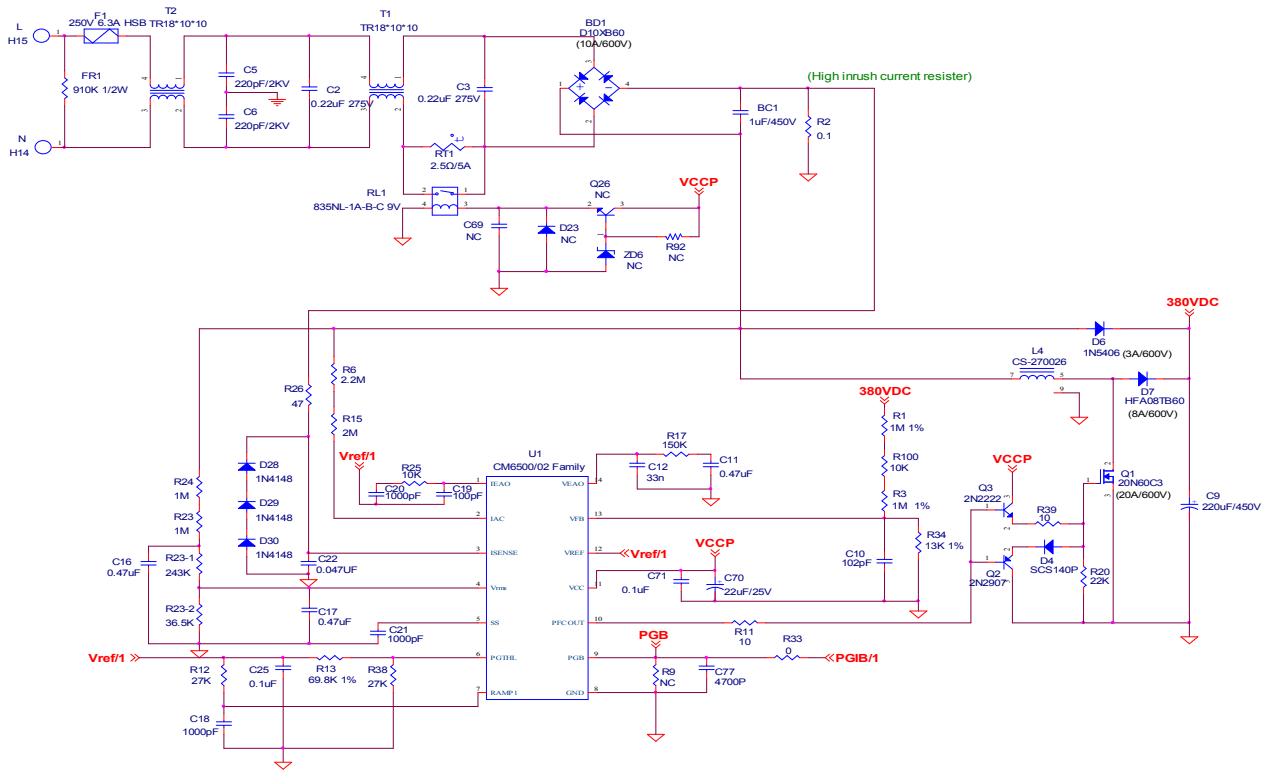

Standby

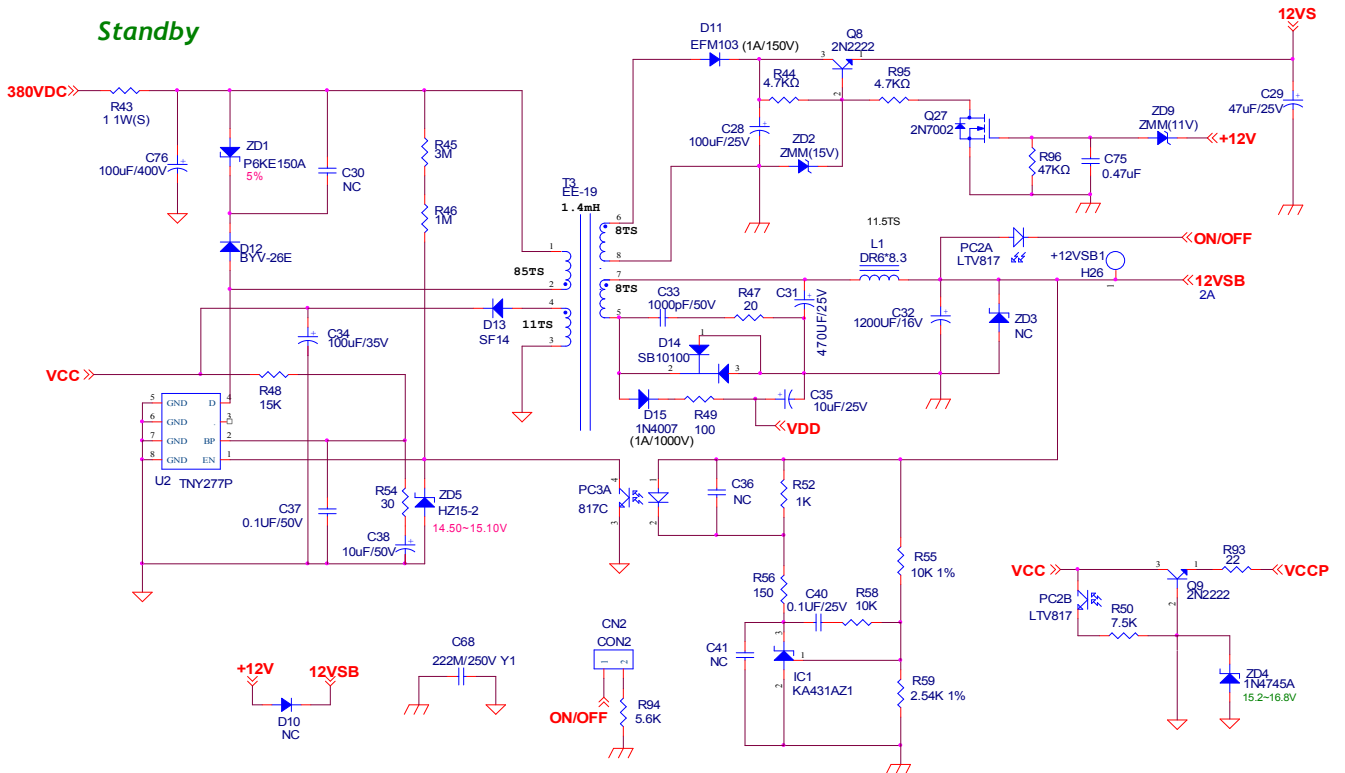

DC-DC

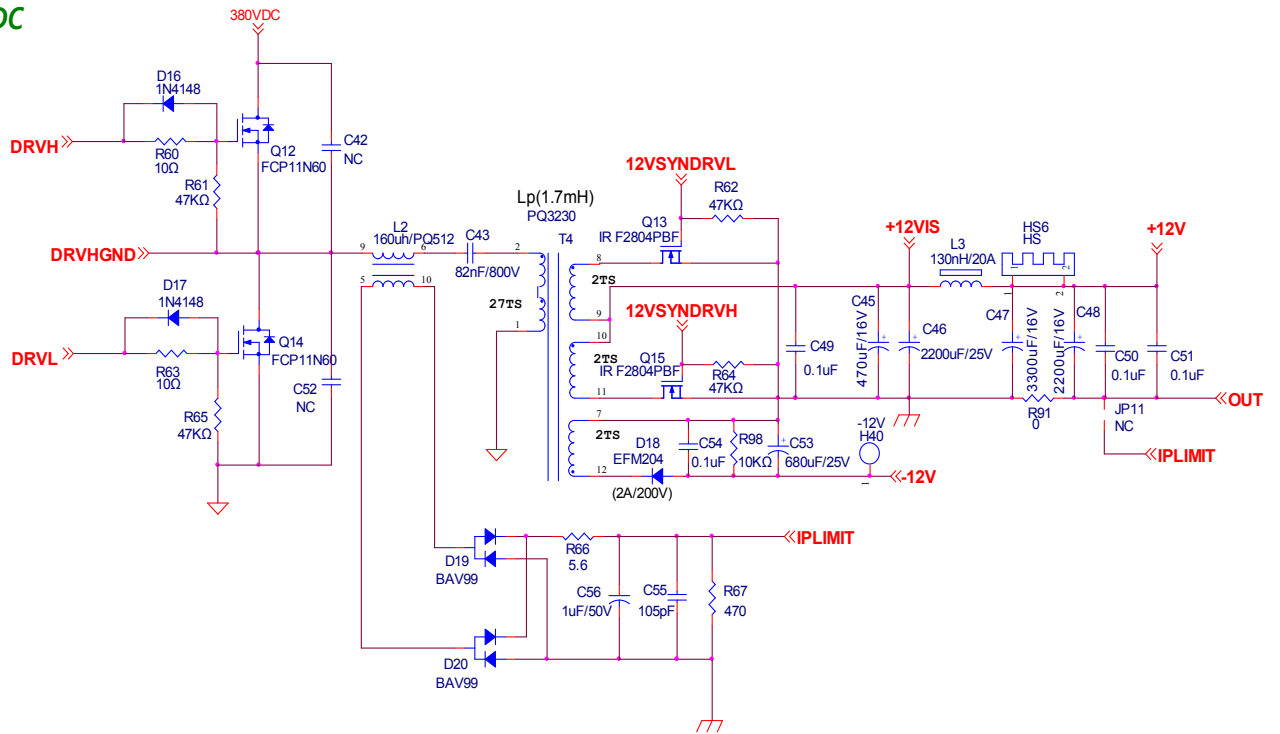

SLS Controller

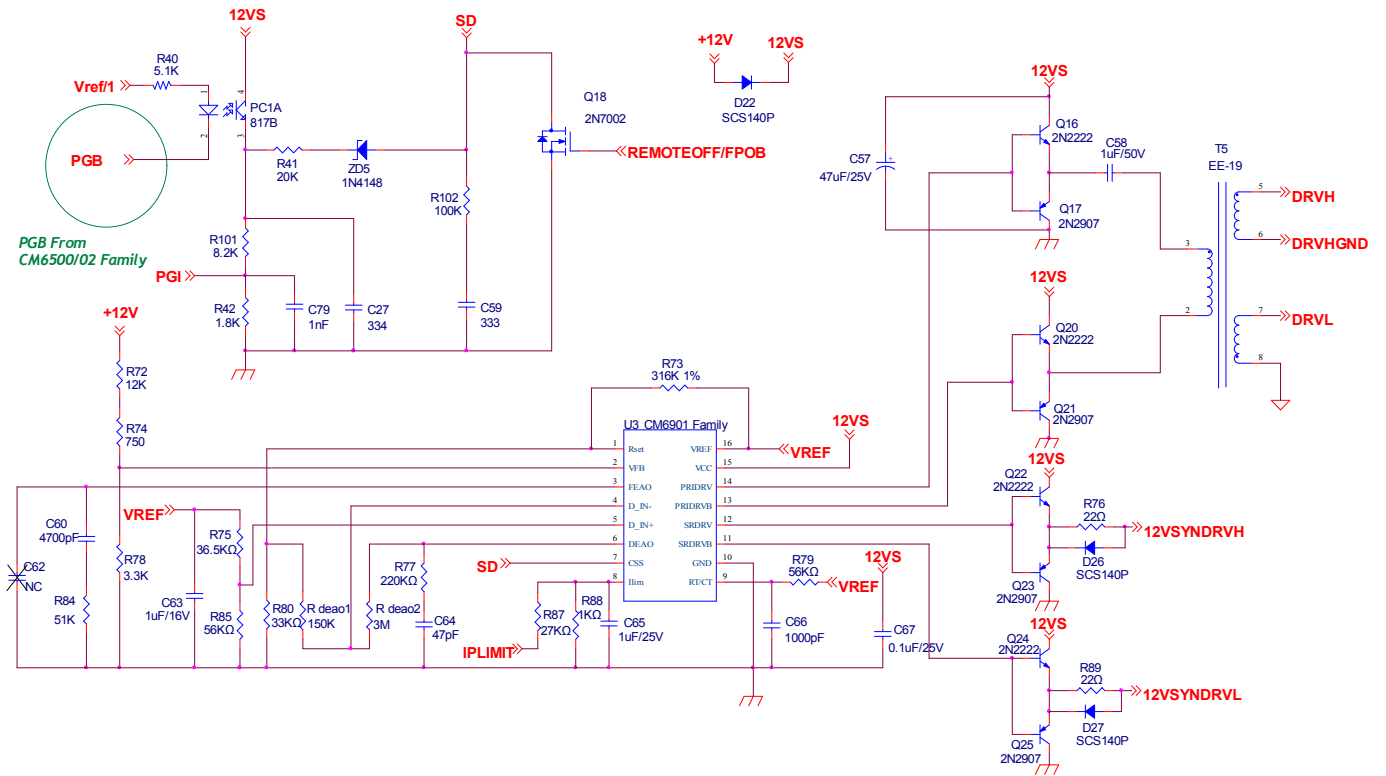

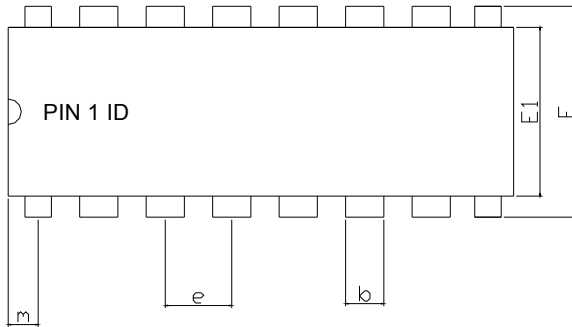
PACKAGE DIMENSION
16-PIN PDIP (P16)

SYMBOLS	DIMENSIONS IN MILLIMETERS			DIMENSIONS IN INCHS		
	MIN	NOM	MAX	MIN	NOM	MAX
A	---	---	4.32	---	---	0.170
A1	0.38	---	---	0.015	---	---
b	1.40	---	1.65	0.055	---	0.065
b1	0.40	---	0.56	0.016	---	0.022
C	0.20	---	0.31	0.008	---	0.012
D	18.79	---	19.31	0.740	---	0.760
E	7.49	---	8.26	0.295	---	0.325
E1	6.09	---	6.61	0.240	---	0.260
e	---	2.54	---	---	0.100	---
L	3.18	---	---	0.125	---	---
m	0.50	---	---	0.02	---	---
θ	0°	---	15°	0°	---	15°

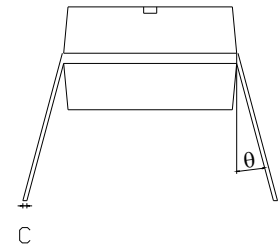
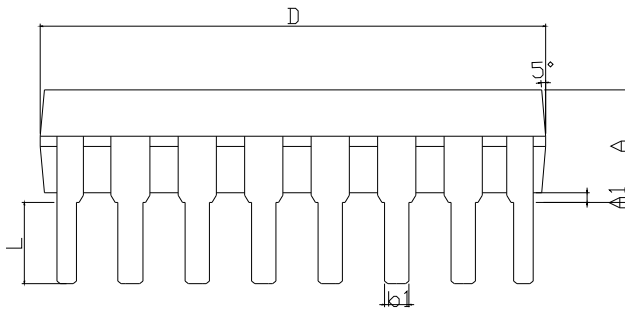
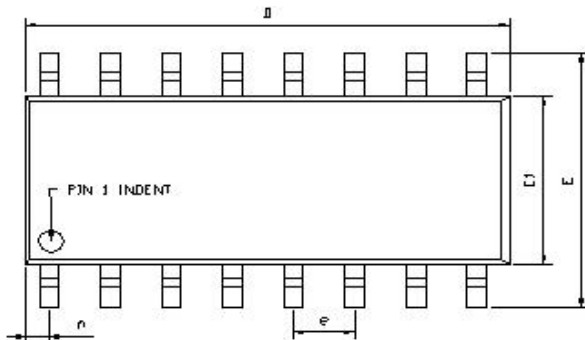
16-PIN SOP (S16)

SYMBOLS	DIMENSIONS IN MILLIMETERS			DIMENSIONS IN INCHS		
	MIN	NOM	MAX	MIN	NOM	MAX
A1	0.10	---	0.25	0.004	---	0.010
A2	1.40	---	1.55	0.055	---	0.061
b	0.30	---	0.51	0.012	---	0.020
C	0.15	---	0.26	0.006	---	0.010
D	9.80	---	10.06	0.386	---	0.396
E	5.79	---	6.20	0.228	---	0.244
E1	3.76	---	4.01	0.148	---	0.158
e	---	1.27	---	---	0.050	---
L	0.38	---	0.69	0.015	---	0.035
m	0.43	---	0.69	0.017	---	0.027
θ	0°	---	8°	0°	---	8°

EXPOSED PAD DIMENSION : (mm)
PAD SIZE: X=2.3, Y=2.6

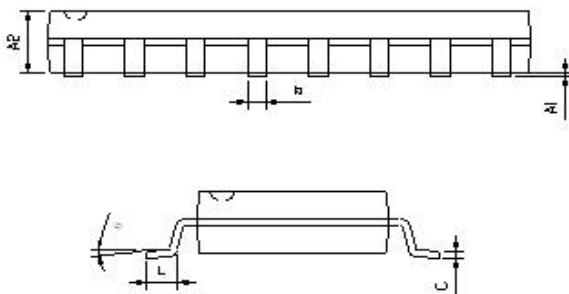
NOTES:

- JEDEC OUTLINE : MS-012 AC
- DIMENSIONS "D" DOES NOT INCLUDE MOLD FLASH, PROTRUSIONS OR GATE BURRS. MOLD FLASH, PROTRUSIONS AND GATE BURRS SHALL NOT EXCEED 0.15mm. PER SIDE.
- DIMENSIONS "E1" DOES NOT INCLUDE INTER-LEAD FLASH, OR PROTRUSIONS. INTER-LEAD FLASH AND PROTRUSIONS SHALL NOT EXCEED 0.25mm PER SIDE.

IMPORTANT NOTICE

Champion Microelectronic Corporation (CMC) reserves the right to make changes to its products or to discontinue any integrated circuit product or service without notice, and advises its customers to obtain the latest version of relevant information to verify, before placing orders, that the information being relied on is current.

A few applications using integrated circuit products may involve potential risks of death, personal injury, or severe property or environmental damage. CMC integrated circuit products are not designed, intended, authorized, or warranted to be suitable for use in life-support applications, devices or systems or other critical applications. Use of CMC products in such applications is understood to be fully at the risk of the customer. In order to minimize risks associated with the customer's applications, the customer should provide adequate design and operating safeguards.

CMC assumes no liability to customer product design or application support. CMC warrants the performance of its products to the specifications applicable at the time of sale.

HsinChu Headquarter

5F, No. 11, Park Avenue II,
Science-Based Industrial Park,
HsinChu City, Taiwan
TEL: +886-3-5679979
FAX: +886-3-5679909

Sales & Marketing

21F., No. 96, Sec. 1, Sintai 5th Rd., Sijhih City,
Taipei County 22102,
Taiwan, R.O.C.
TEL: +886-2-2696 3558
FAX: +886-2-2696 3559
