

## Features

- Wide 5V to 32V Input Voltage Range
- Output Current Sense Voltage is 0.24V
- Minimum Drop Out 0.3V
- Fixed 380KHz Switching Frequency
- 1.5A Constant Output Current Capability
- Internal Optimize Power MOSFET
- Excellent line and load regulation
- High efficiency up to 96%
- TTL shutdown capability
- EN pin with hysteresis function
- Built in thermal shutdown function
- Built in current limit function
- SOIC-8 package

## General Description

The XL3002 is a 380 KHz fixed frequency PWM buck (step-down) DC/DC converter, capable of driving a 1.5A load with high efficiency, low ripple and excellent line and load regulation. Requiring a minimum number of external components, the regulator is simple to use and include internal frequency compensation and a fixed-frequency oscillator.

The PWM control circuit is able to adjust the duty ratio linearly from 0 to 100%. An enable function, an over current protection function is built inside. An internal compensation block is built in to minimize external component count.

## Applications

- MR16 LED Lamp
- LED Lighting



SOIC-8

Figure1. Package Type of XL3002

**1.5A 380KHz 32V Buck LED Constant Current Driver**

**XL3002**

**Pin Configurations**

CS	1	8	GND
EN	2	7	GND
	XL3002		
NC	3	6	SW
VIN	4	5	SW

Figure2. Pin Configuration of XL3002 (Top View)

Table 1 Pin Description

Pin Number	Pin Name	Description
1	CS	Output constant current sense Pin (CS). The CS reference voltage is 0.24V.
2	EN	Enable Pin. Drive EN pin low to turn off the device, drive it high to turn it on.
3	NC	No connected.
4	VIN	Supply Voltage Input Pin. XL3002 operates from a 5V to 32V DC voltage.
5,6	SW	Power Switch Output Pin (SW). Output is the switch node that supplies power to the output.
7,8	GND	Ground Pin.

**Function Block**

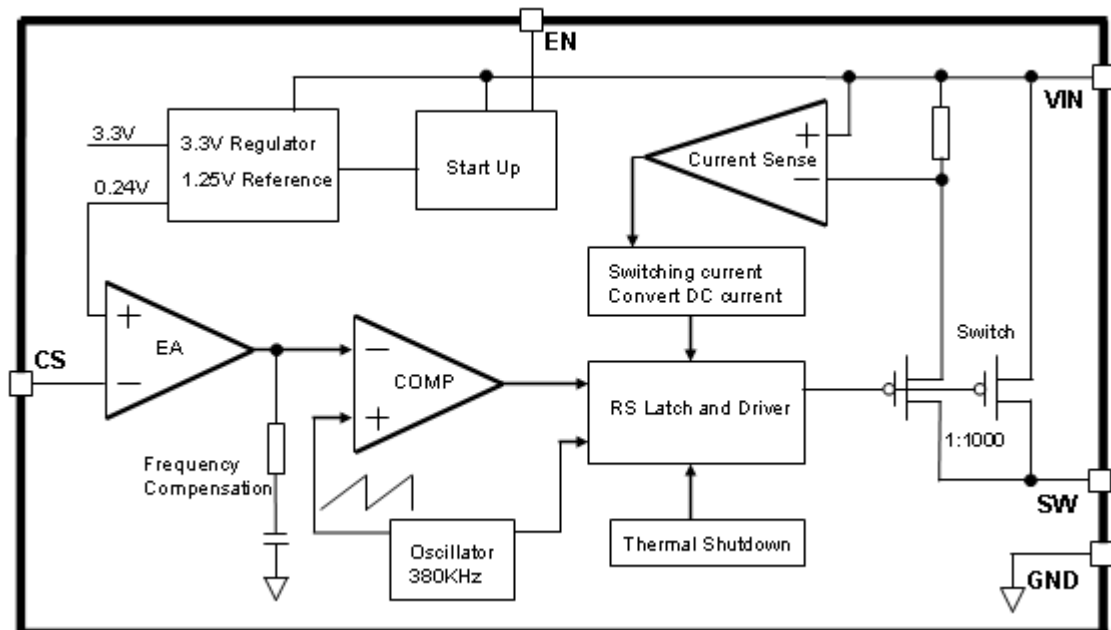

Figure3. Function Block Diagram of XL3002

**Typical Application Circuit (MR16 LED Lamp)**

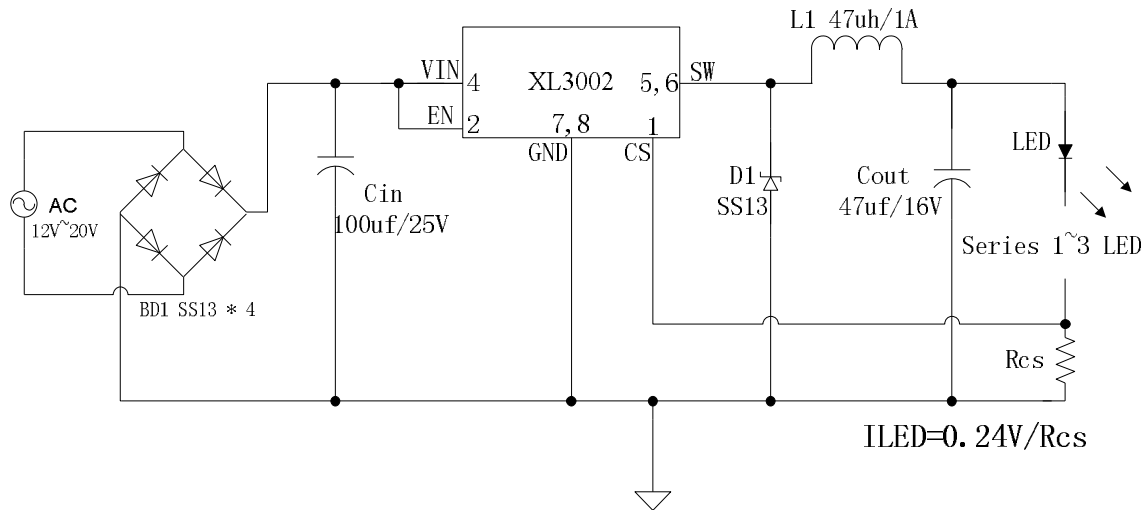

Figure4. XL3002 Typical Application Circuit (MR16 LED Lamp)

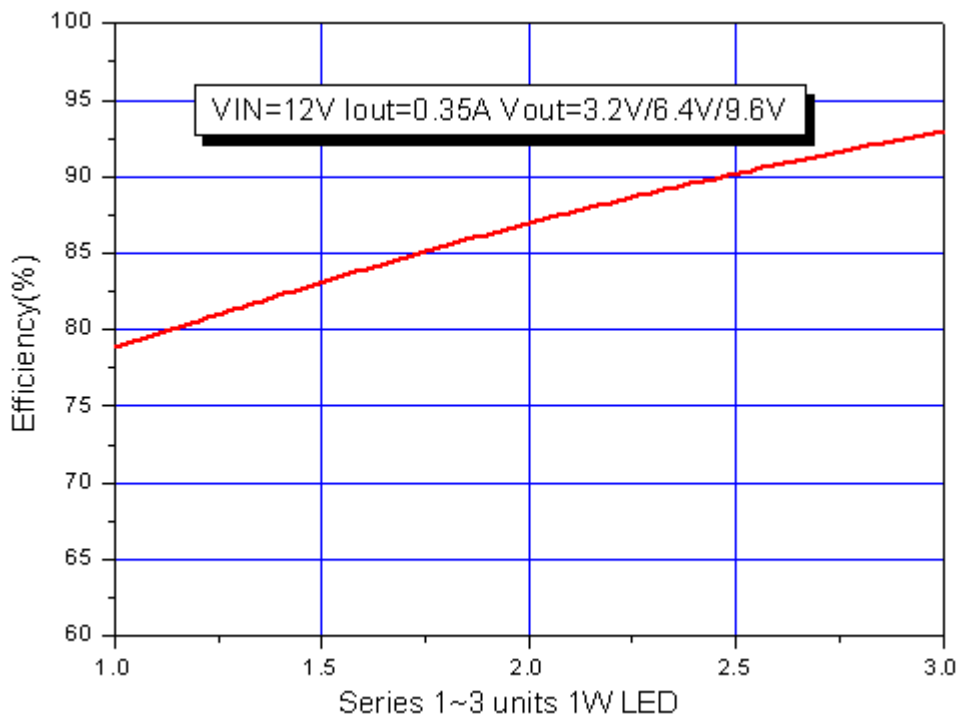

Figure5. XL3002 Typical Application Circuit Efficiency

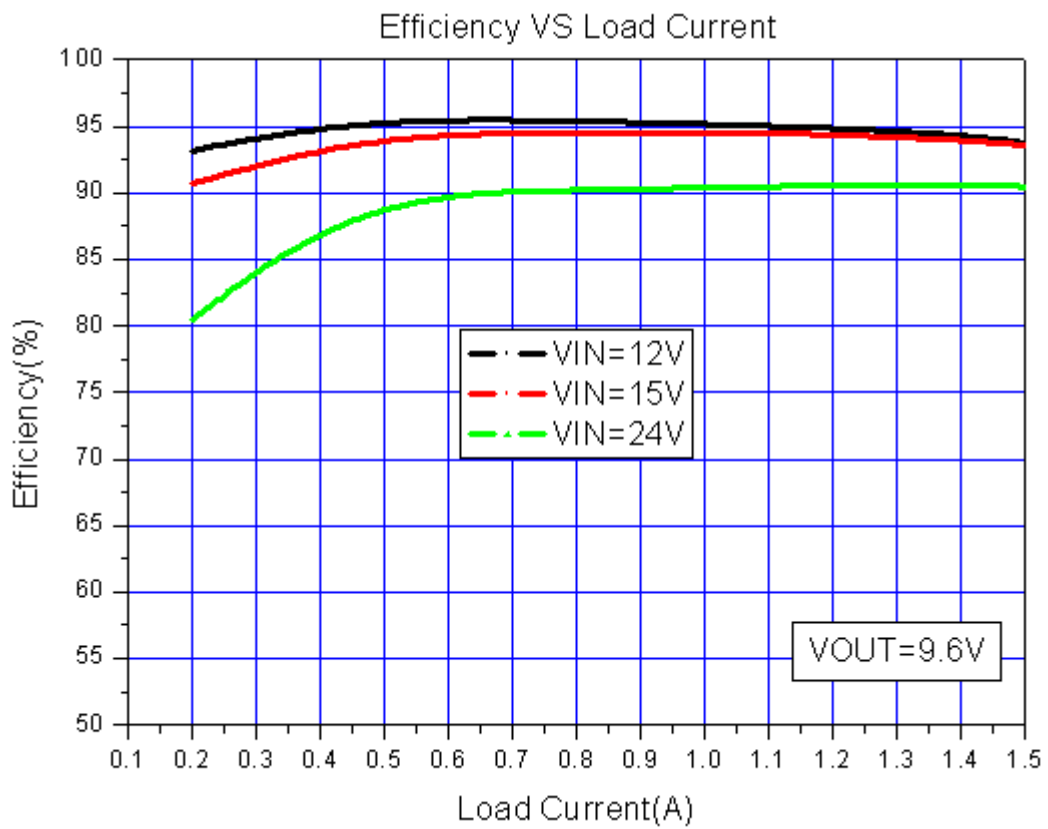

Figure6. XL3002 Efficiency VS Load current & Input voltage

**1.5A 380KHz 32V Buck LED Constant Current Driver**

**XL3002**

**Ordering Information**

Order Information	Marking ID	Package Type	Packing Type Supplied As
XL3002E1	XL3002E1	SOIC-8	2500 Units on Tape & Reel

XLSEMI Pb-free products, as designated with “E1” suffix in the par number, are RoHS compliant.

**Absolute Maximum Ratings (Note1)**

Parameter	Symbol	Value	Unit
Input Voltage	V <sub>IN</sub>	-0.3 to 36	V
CS Pin Voltage	V <sub>CS</sub>	-0.3 to V <sub>IN</sub>	V
EN Pin Voltage	V <sub>EN</sub>	-0.3 to V <sub>IN</sub>	V
SW Pin Voltage	V <sub>SW</sub>	-0.3 to V <sub>IN</sub>	V
Power Dissipation	P <sub>D</sub>	Internally limited	mW
Thermal Resistance (Junction to Ambient, No Heatsink, Free Air)	R <sub>JA</sub>	100	°C/W
Operating Junction Temperature	T <sub>J</sub>	-40 to 125	°C
Storage Temperature	T <sub>STG</sub>	-65 to 150	°C
Lead Temperature (Soldering, 10 sec)	T <sub>LEAD</sub>	260	°C
ESD (HBM)		3000	V

**Note1:** Stresses greater than those listed under Maximum Ratings may cause permanent damage to the device. This is a stress rating only and functional operation of the device at these or any other conditions above those indicated in the operation is not implied. Exposure to absolute maximum rating conditions for extended periods may affect reliability.

**1.5A 380KHz 32V Buck LED Constant Current Driver**

**XL3002**

**XL3002 Electrical Characteristics**

T<sub>a</sub> = 25°C; unless otherwise specified.

Symbol	Parameter	Test Condition	Min.	Typ.	Max.	Unit
<i>System parameters test circuit figure4</i>						
VCS	Current Sense Voltage	V <sub>in</sub> = 8V to 32V, V <sub>out</sub> =5V I <sub>load</sub> =0.3A	0.228	0.24	0.252	V
Efficiency	η	V <sub>in</sub> =12V , V <sub>out</sub> =9.6V I <sub>out</sub> =1A	-	96	-	%

**Electrical Characteristics (DC Parameters)**

V<sub>in</sub> = 12V, GND=0V, V<sub>in</sub> & GND parallel connect a 220uf/25V capacitor; I<sub>out</sub>=500mA, T<sub>a</sub> = 25°C; the others floating unless otherwise specified, system parameters reference figure4.

Parameters	Symbol	Test Condition	Min.	Typ.	Max.	Unit
Input operation voltage	V <sub>in</sub>		5		32	V
Shutdown Supply Current	I <sub>STBY</sub>	V <sub>EN</sub> =0V		60	200	uA
Quiescent Supply Current	I <sub>q</sub>	V <sub>EN</sub> =2V, V <sub>FB</sub> =V <sub>in</sub>		2.5	5	mA
Oscillator Frequency	F <sub>osc</sub>		304	380	456	KHz
EN Pin Threshold	V <sub>EN</sub>	High (Regulator ON) Low (Regulator OFF)		1.7 1.1		V
Output Power PMOS	R <sub>DS(ON)</sub>	V <sub>FB</sub> =0V I <sub>SW</sub> =1A		150	250	mohm

**Schottky Diode Selection Table**

Current	Surface Mount	Through Hole	VR (The same as system maximum input voltage)				
			20V	30V	40V	50V	60V
1A		✓	1N5817	1N5818	1N5819		
	✓		SS12	SS13	SS14	SS15	SS16
3A		✓	1N5820	1N5821	1N5822		
		✓	MBR320	MBR330	MBR340	MBR350	MBR360
	✓		SK32	SK33	SK34	SK35	SK36
	✓			30WQ03	30WQ04	30WQ05	
		✓		31DQ03	31DQ04	31DQ05	
		✓	SR302	SR303	SR304	SR305	SR306

